

ZAF100B Camera Series

Bullet Proof
Camera Housing



Mechanical

Housing	Stainless steel 304 or 316L
IP	IP68
Cable thread hole	2pcs G3/4 or NPT3/4

Ambient

Ambient temperature	-25 to +60°C
Air pressure	80Kpa to 106Kpa
Relative Humidity	≦ 95% (no condensation)

General

Size	472*195*194mm
Inner space	210*80*80mm
Weight	11.5kg
Mounted	wall, pole
Wall bracket	ZAZ100B

Structure and Dimensions

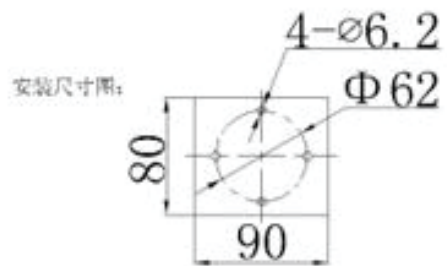
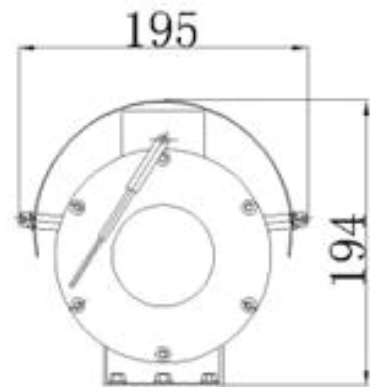
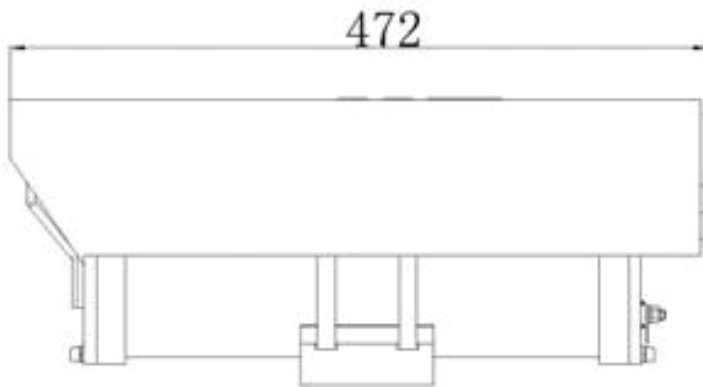



ZAF100B Wall Bracket

General

Material	Stainless steel 304 or 316L
Flexible Joint	Yes
Max Loading	100kg
Weight	2.7kg
Fit	ZAF100,ZAF102, ZAF105, ZAF103, ZAF1031, ZAF1032, Z AFC106

Dimension

